

PIATF ORM

A NEWSLETTER FOR OUR EMPLOYEES AND PARTNERS

FROM OUR

PERSPECTIVE

KINZLER CONSTRUCTION SERVICES
ANNUAL CUSTOMER APPRECIATION
STEAK LUNCH & PRODUCT FAIR

Friday, October 19th

11 am - 2pm

2335 230th Street

Ames office | warehouse

- 11:30 to 1:30 enjoy the customer appreciation steak lunch

- 11:00 to 2:00 visit all 15 vendor booths, tour the Kinzler warehouse, foam trailer, machine center, and don't forget to register for prizes

NEW THIS YEAR!

- cutting edge products and applications will be highlighted on the stage in the new Kinzler Training Center for quick, informative presentations, watch the mail for your invitation and presentation schedule



Thanks to our customers, vendors, and employees 2007 is shaping up to be a very successful and exciting year at Kinzler Companies.

Our most significant growth areas have been in the areas of commercial construction project services, and our patented insulation system for metal buildings, High-R. Our High-R system division has sold and installed more than double the square footage of the prior year.

The focus of our management team as of late has largely been on strengthening our resources, training, and culture to better serve our customer base. The addition of our new Ames employee training center (pictured at right) allows more consistent and robust training and safety initiatives resulting in more consistent, quality conscious, and safe delivery of our products and services. During the second quarter of this year we completed an expansion of our main warehouse facility consisting of 25,000 additional square feet of warehouse floor and ten additional loading docks. This allows us to better serve our growing customer base and gives us the ability to increase product offerings while affording a safer, more comfortable, and more efficient work environment for our warehouse staff.

Our fireproofing division recently invested in an additional pump rig that has expanded our capabilities to deliver a variety of fireproofing products effectively on more demanding sites. More to come on fireproofing in our next newsletter.

I hope you can join us for our annual steak lunch and product fair on October 19th. We look forward to showing you the growth and change around our facilities. 

Kind Regards,

Tanner J. Kinzler



OVERVIEW & UNDERWAY

FEATURED PRODUCT

CLARK WESTERN introduces..... RED HEADER RO (Rough Opening System)

- framing around a non load bearing door or window using single members in lieu of a built-up header or jamb system
- can be used for exterior and interior framing
- eliminates and/or minimizes built up jambs and headers
- header and jamb system has: extra wide flanges (3" and 3 1/2") and extra long returns (1")
- the Drop'N Lock Clip connects the header to the jamb with ease
- system saves labor on installation and handling

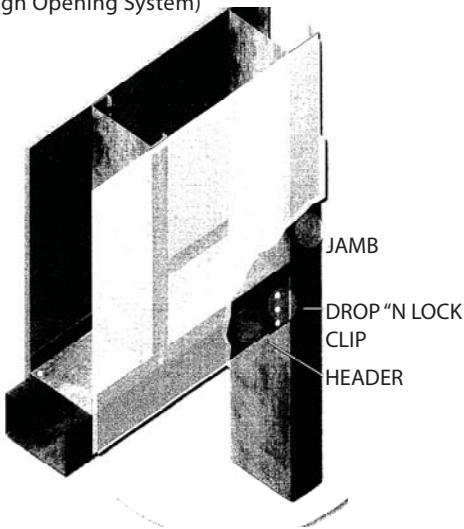

call us at: 888 292 2382 for more information

FEATURED PROJECTS



INGERSOLL SQUARE: des moines, ia
FEATURED: wall insulation



4TH & COURT LOFTS: des moines, ia
FEATURED: wall and ceiling insulation



SPAGHETTI WORKS: des moines, ia
FEATURED: foam, firm fill, and sound mat



DRAKE HOUSING PROJECT: des moines, ia
FEATURED: material supply

New....

FACES



We are pleased to introduce our new Sales Representative, Doug Meyer. Doug is a Wisconsin Native, but has lived in Iowa for 20 years. He attended the University of Wisconsin-Milwaukee, before going to work for Caterpillar Tractor Co. for six years. He left Caterpillar to start a career in insurance, which lasted over 20 years. He has worked as an agent wholesaler, manager, and finally director of life sales for the western part of the country. He decided to pursue a change of careers and joined Kinzler Companies on January 1, 2007 as commercial sales manager. His main role is serving our commercial contractor clients throughout the state of Iowa. He and his wife Debbie have been married for 31 years and have two children, Dan who has recently graduated from the University of Iowa and Lindsey, who is a senior at the University of Iowa. In his spare time, he enjoys golfing, fishing and spending time on his acreage in rural Madison County. We are excited to have him join Kinzler Companies. Welcome Doug!



Exciting....

NEWS

In June 2007, we had two of our employees attend the Advanced Applicator Training program for polyurethane foam in Phoenix, AZ. We are excited to announce that both Joey Lay and Lyle Scandrett are now UCSC Certified Applicators. To achieve this certification they had to have an average of 70% or above on the written test scores, average of good or better on the trouble shooting and spray ability and inspected by an UCSC representative and approval on three completed spray projects. This will assure you, the customer, the quality installation you expect.



warehouse..

COMPLETE

kinzler
COMPANIES

Learn more @ www.kinzlercompanies.com
P 515.292.5714 T 888.292.2382